

Since the usage and finishing of the product is not under our control, we accept no liability for the success of the work and can therefore only guarantee the nature of our products as per the accompanying product data sheets and in accordance with our general terms and conditions of sale. The properties listed here represent no guarantee with respect to the eventual use of our products. We reserve the right to make changes due to technical advances. Any other technical information given in the course of a consultation must be confirmed in writing. Colours shown here are restricted by the printing techniques and may differ from those exhibited by the products themselves. We also reserve the right to make alterations to the product technology or design. Only the current version of this data sheet is valid. Such versions are accessible by anyone via the internet. The issue of the latest data sheet invalidates all those that have been published beforehand.

DUROSOL

1/2

Square Edge profiles made of PVC

- Information Sheet -

DURAL

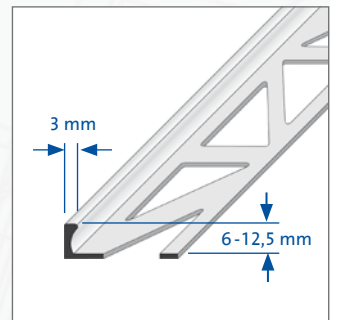
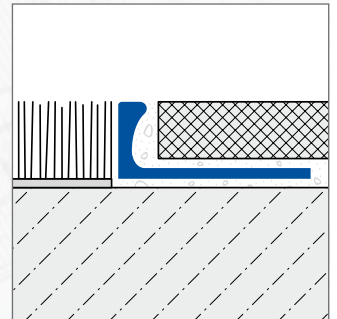
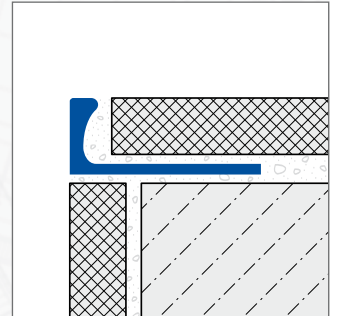

APPLICATION:

DUROSOL PVC Square Edge profiles by Dural are used for decorative edge protection. They are made of PVC and are available in a variety of colours. This allows colour matching of the profiles to tiles or grout joints. Alternatively contrasts can be created for a decorative effect.

DUROSOL PVC is also suitable for bordering of carpets, natural stone or epoxy flat coats in the wall area. They effectively prevent damage of the covering.

MATERIAL:

DUROSOL PVC is available in the following versions: As PVC Standard in following colors: white, jasmine, beige, black, pergamon light, grey, ivory, pergamon, silver grey and in marble effects high gloss („Star“ with peel-off strip): white, beige, grey and black.

PROPERTIES:

DUROSOL PVC profiles are especially appropriate for decorative use. They are manufactured in solid colour PVC and are mostly UV-stable. In external areas, subject to bright sunlight, some fading in the intensity of colours should be expected. Damage due to impact or scratching is unlikely within normal conditions of use. DUROSOL PVC profiles are not appropriate for corners and edges submitted to special stresses. N.B.: The use of coloured mortar with ultra fine colour pigments in conjunction with plastic profiles may result in permanent staining of the profiles. We recommend taking appropriate protective measures as a precaution.

For all products and materials, the following applies: The suitability of the material with regard to the expected mechanical loading and chemical exposure must be investigated carefully in each individual case. The generally recognised rules of good engineering practice must always be observed!

DURAL GmbH

Südring 11

D-56412 Ruppach-Goldhausen

Tel. +49 (0) 2602/9261-0

Fax +49 (0) 2602/9261-50

info@dural.com

Square Edge profiles made of PVC

- Information Sheet -

HANDLING:

1. Select the DUROSOL Square Edge profile according to the thickness of tiles.
2. Apply tile cement in the appropriate area using a notched trowel. In the case of external corner edges, first finish tiling of one wall.
3. Press the DUROSOL profile into the cement bed and align.
4. Completely cover the fixing legs.
5. Leaving a joint of 2-3 mm between tiles and profile.
6. Press the tiles solidly into the cement bed and align flush with the upper profile edge.
7. Completely fill the space between tiles and profile with joint mortar.

MAINTENANCE:

DUROSOL PVC profiles do not require any special care. Dirt deposits can be removed with usual commercial cleaning materials. The cleaning materials have to be free of hydrochloric acid and hydrofluoric acid and must not be abrasive.

DATA SHEET:

MATERIAL:	PVC standard colours or PVC marble effects high gloss („Star“with peel-off strip)
LENGTH:	250 cm
VISIBLE WIDTH:	3 mm
HEIGHT:	6 / 8 / 10 / 12,5 mm (standard colours) , 6 / 8 / 10 mm (marble effects)

DURAL GmbH

Südring 11

D-56412 Ruppach-Goldhausen

Tel. +49 (0) 2602/9261-0

Fax +49 (0) 2602/9261-50

info@dural.com